



5  
Year  
Warranty

## D(M)S24-27 Series — Installation Instructions

06/30/22

### Applications

The D(M)S24-27 Series Electric Spring Return Actuators are actuators that operate on AC/DC 24 V power as well as a 120/240 VAC model. These bidirectional actuators do not require a damper linkage, and are easily installed on round shafts from 1/4 to 1/2 in. (6 to 12 mm) or square shafts from 1/4 to 5/16 in. (6 to 8 mm) using the standard shaft clamp included with the actuator.

A single D(M)S24-27 Series Electric Spring Return Actuator provides 27 lb-in. (3 N·m) running and spring return torque. An integral line voltage auxiliary switch, available only on the (-A) models, indicates end-stop position, or performs switching functions within the selected rotation range.

DS24-27-T and DMS24-27 actuators include plenum-rated cables and are specially configured for installation in spaces used for environmental air-handling purposes other than ducts and plenums as specified in National Fire Protection Association (NFPA) 70: National Electrical Code section 300.22(C), Other Space Used for Environmental Air. The space over a hung ceiling used for environmental air handling purposes is an example of the type of space for which these actuators are configured.

### IMPORTANT:

Use this The D(M)S24-27 Series Electric Spring Return Actuator only to control equipment under normal operating conditions. Where failure or malfunction of the actuator could lead to personal injury or property damage to the controlled equipment or other property, additional precautions must be designed into the control system. Incorporate and maintain other devices, such as supervisory or alarm systems or safety or limit controls, intended to warn of or protect against failure or malfunction of the actuator.

### Installation

The D(M)S24-27 Series Electric Spring Return Actuators mount directly to the surface in any convenient orientation using two No. M3.5 x 9.5 mm self-drilling sheet metal screws and the anti-rotation bracket (parts included with the actuator). No additional linkages or couplers are required. Electrical connections are color-coded and identified with numbers permanently marked on the actuator cable. A tag on the actuator cable identifies the electrical connections and wiring details are included on the actuator housing.

### IMPORTANT:

Do not install or use this D(M)S24-27 Series Electric Spring Return Actuator in or near environments where corrosive substances or vapors could be present. Exposure of the electric actuator to corrosive environments may damage the internal components of the device, and will void the warranty.

### Parts Included

- D(M)S24-27 Series actuator
- Adjustable stop kit
- Anti-rotation bracket with two No.M3.5 x 9.5 mm, pan-head, cross-recessed (Phillips), self-drilling and self-tapping screws

### Special Tools Needed

- 10 mm wrench/socket
- Drill with Phillips bit, driver size 1



# D(M)S24-27 Series — Installation Instructions - Continued

## Dimensions

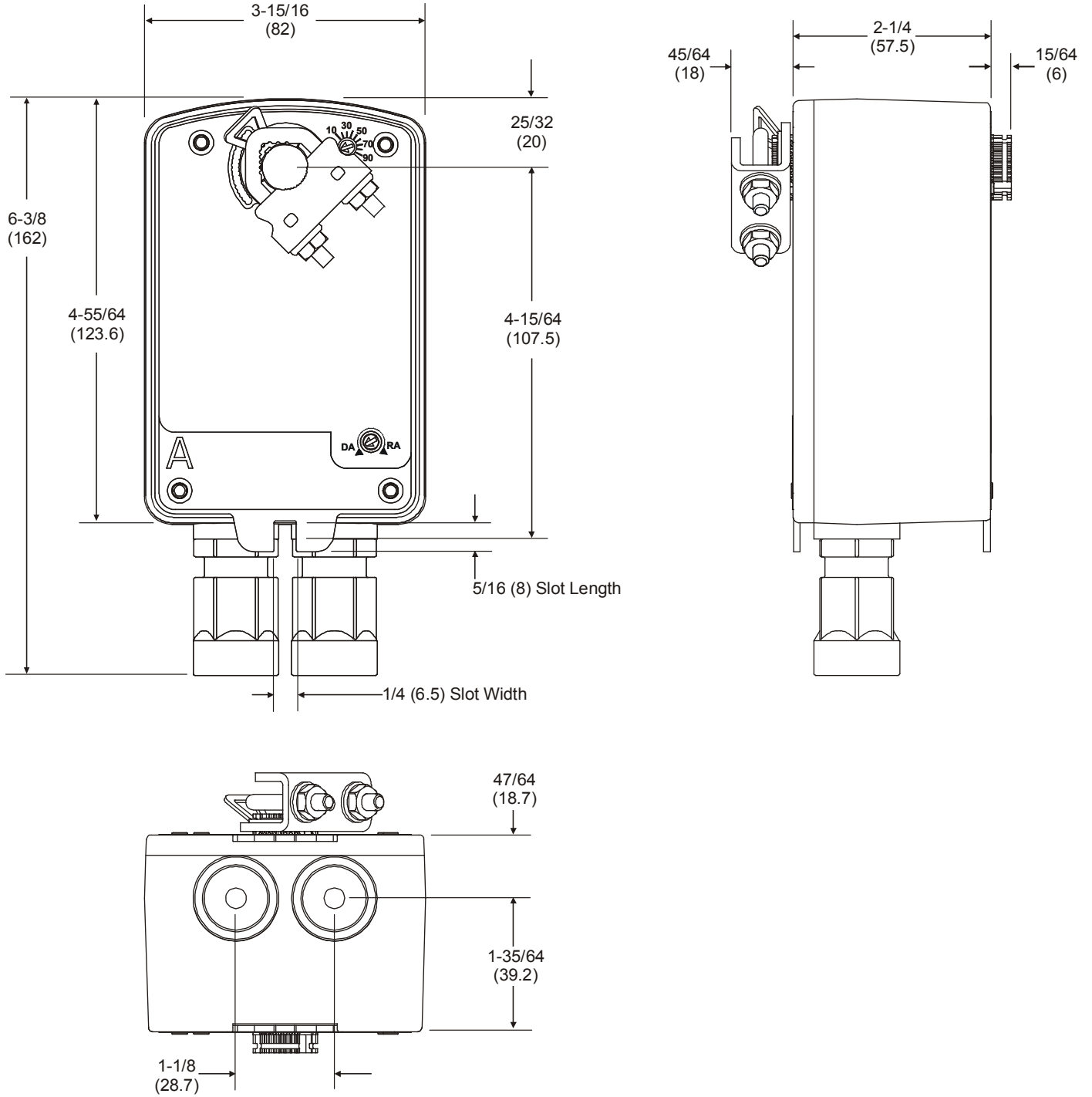



## Mounting and Installation

The D(M)S24-27 Series Electric Spring Return Actuators can be easily installed on dampers with round shafts from 1/4 to 1/2 in. (6 to 12 mm) or square shafts from 1/4 to 5/16 in. (6 to 8 mm) using the standard shaft coupler included with the actuator.

If the damper shaft extends less than 3.31 in. (84 mm), see the Removable Coupler section for further instructions. If the damper shaft extends less than 0.79 in. (20 mm), install a shaft extension recommended by the damper manufacturer.

### Counterclockwise (CCW) Spring Return Direction – Clockwise (CW) Powered Operation

For CCW spring return direction, mount the actuator to the damper shaft so that Side A of the actuator is away from the damper as illustrated in Figure 2. With power applied, the actuator drives CW from the 0° position and spring returns CCW.

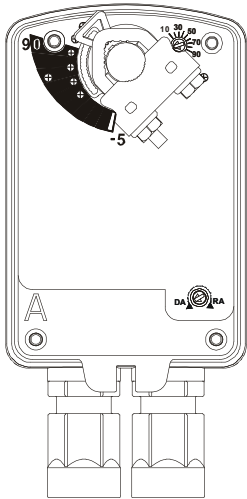

Figure 2: Actuator Side A

### Clockwise (CW) Spring Return Direction – Counterclockwise (CCW) Powered Operation

For CW spring return direction, mount the actuator to the damper shaft so that Side B of the actuator is away from the damper as illustrated in Figure 3. With power applied, the actuator drives CCW from the 0° position and spring returns CW.

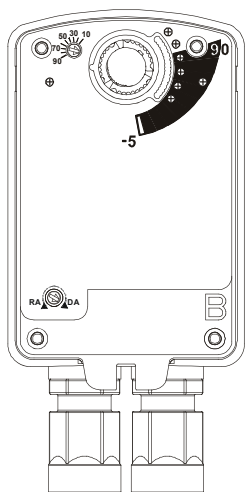

Figure 3: Actuator Side B

### Removable Coupler

If the damper shaft extends less than 3.31 in. (84 mm), mount the coupler on the face of the actuator closest to the damper.

If the damper shaft extends less than 0.79 in. (20 mm), a shaft extension is required to mount the actuator.

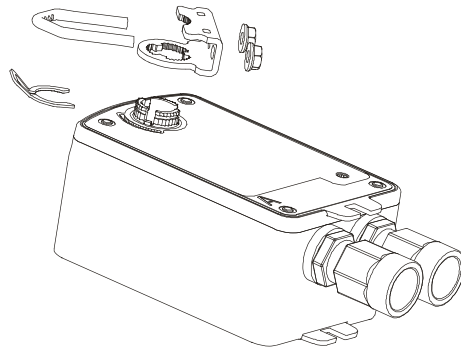

Figure 4: Changing the Coupler Position

To change the coupler's position, see Figure 4 and proceed as follows:

1. Mount the coupler on either Side A or Side B of the actuator as determined by the shaft length.
2. Snap the locking clip securely into the coupler retention groove to retain the coupler.

### Mounting the Actuator

To mount the actuator, proceed as follows:

1. See the dimensions in Figure 5 and Table 2 to ensure the correct positioning of the anti-rotation bracket.

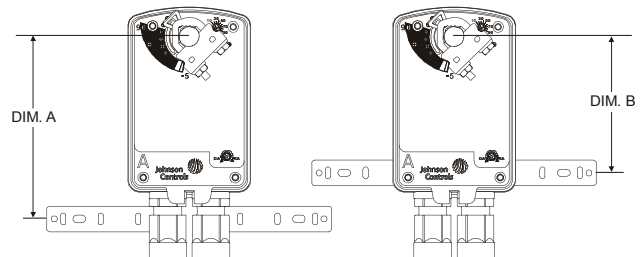

Figure 5: Positioning the Anti-Rotation Bracket

Table 2: Dimensions from Anti-Rotation Bracket to Shaft Center

Shaft Diameter, in. (mm)	Dimension A, in. (mm)	Dimension B, in. (mm)
1/4 to 1/2 (6 to 12)	4-27/32 (123)	3-5/8 (92)



**IMPORTANT**

The tab on the anti-rotation bracket must fit midpoint in the actuator slot. Positioning the tab midpoint in the slot prevents actuator binding and premature wear, and makes actuator removal easier.

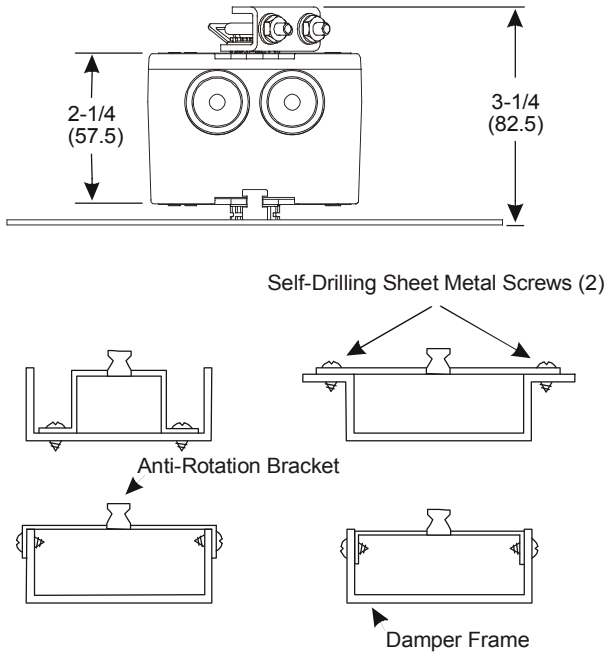

**Figure 6: Anti-Rotation Mounting Bracket Positions**

2. Bend or cut the anti-rotation bracket to fit the damper frame or duct as illustrated in Figure 6.

**Note:** The anti-rotation bracket can be bent to fit a round damper.

3. Mark or drill mounting holes in the damper frame or duct using the anti-rotation bracket as a guide (based on the measurements obtained in Table 2 and Figure 5).

4. Secure the anti-rotation bracket to the damper frame or duct using the two No. M3.5 x 9.5 mm self-drilling sheet metal screws provided.

**IMPORTANT**

Do not overtighten the mounting screws to avoid stripping the threads. Be certain that the tab on the anti-rotation bracket remains properly positioned in the slot on the actuator, and that the actuator remains parallel to the mounting surface.

- Slide the actuator onto the damper shaft, and position the anti-rotation bracket tab into the slot at the bottom of the actuator as illustrated in Figure 6.
- Rotate the damper blade(s) to the desired position if the power is lost.
- Hold the actuator perpendicular to the damper shaft. Evenly hand-tighten each nut on the coupler U-bolt, then torque the coupler U-bolt nuts to 100 to 125 lb-in. (11 to 14 N·m).
- Apply power long enough for the actuator to travel a full stroke. Verify that the actuator rotates freely throughout the range.

**Limiting Rotation Range Using the Adjustable Stop Kit**

The actuator is factory set for 95° rotation, and its range is limited in 5° increments to a minimum of 35°. A stroke-limiting stop can be attached in the field to the shaft coupler side of the actuator to reduce the rotation range. Attaching the stroke-limiting stop in the furthest mounting position reduces the rotation range of the actuator by 5°. Each progressive mounting position reduces the rotation range an additional 5°.

- Check that the damper blade is visible or its position is permanently marked on the end of the damper shaft, as illustrated in Figure 7.

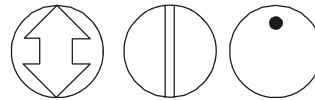

**Figure 7: Damper Position Icons**

- Position the stroke-limiting stop in the serrated slot with its leading edge at the scale position matching the desired stroke.
- The product label marks hole positions for the M3-0.5 x 8mm self-tapping screw provided with the adjustable stop kit. Drive the screw through the slot in the adjustable stop and into the actuator face over a marked hole position. (See Figure 8.)

**Note:** The minimum rotation range is 35°.

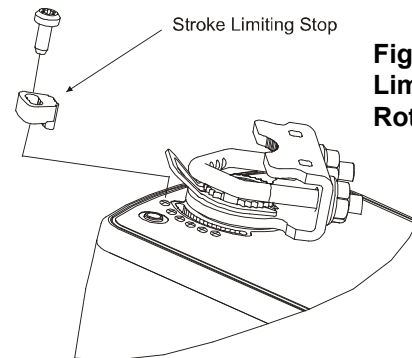

**Figure 8: Limiting Rotation Range**



# D(M)S24-27 Series — Installation Instructions - Continued

## Wiring (Cable)

### IMPORTANT:

Do not install multiple D(M)S-27 Series Actuators connected to the same mechanical load. Master-Slave application of D(M)S-27 Series Actuators requires that each actuator be connected to independent loads.



#### WARNING: Risk of Electric Shock.

Disconnect or isolate all power supplies before making electrical connections. More than one disconnection or isolation may be required to completely de-energize equipment. Contact with components carrying hazardous voltage can cause electric shock and may result in severe personal injury or death.



#### CAUTION: Risk of Property Damage.

Do not apply power to the system before checking all wiring connections. Short circuited or improperly connected wires may result in permanent damage to the equipment.

### DS24-27-(A)

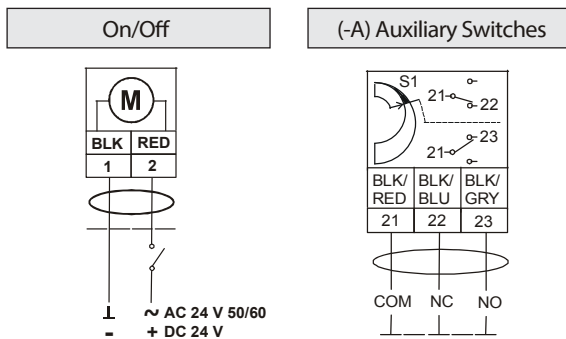

### DSU20-27-(A)

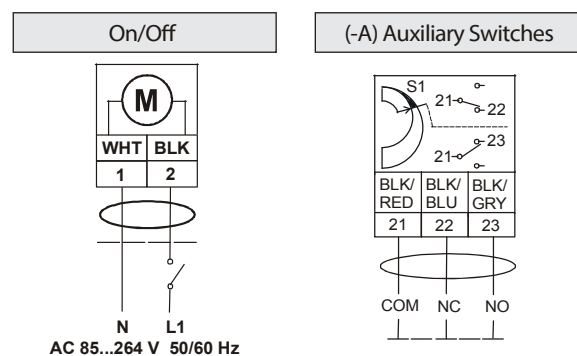

### DS24-27-T(A)

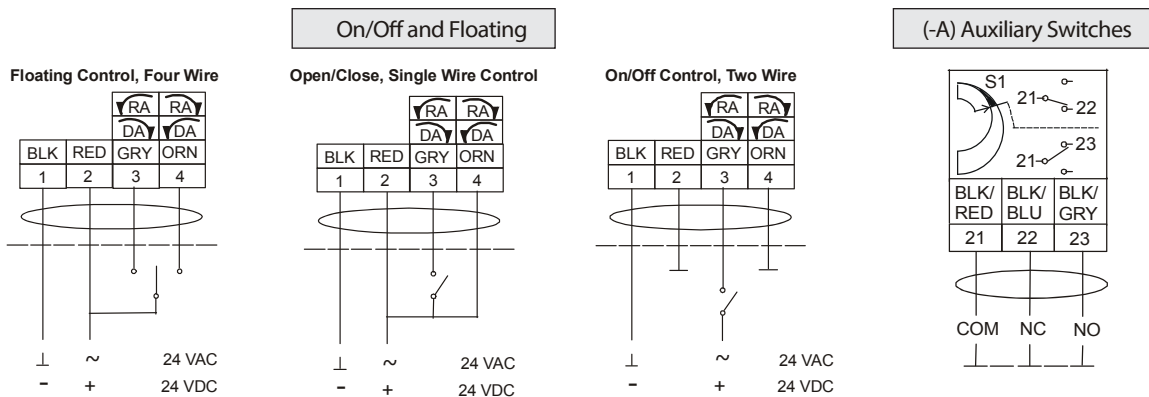

### DMS24-27(A)

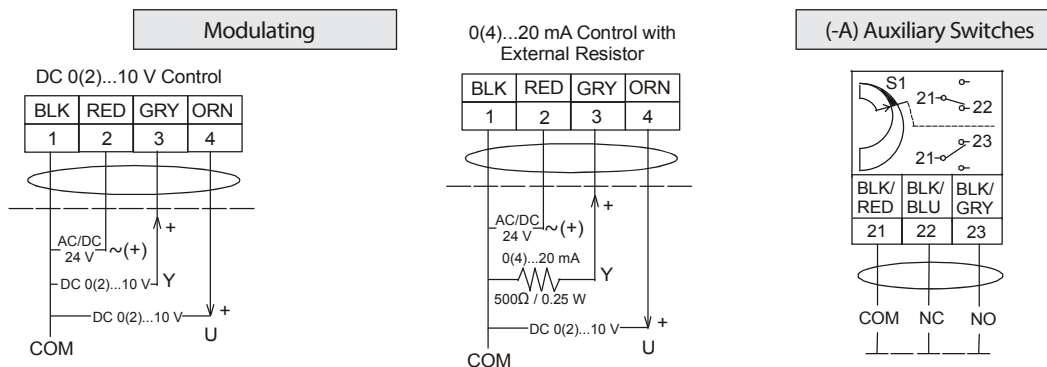



### Using Conduit

All D(M)S24-27 Series Actuators accept 1/2 in. threaded electrician's fittings.

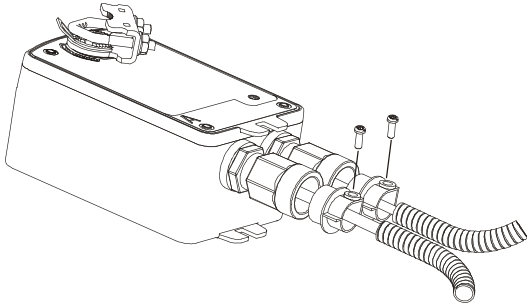

**Figure 11: Adding Flexible Metal Conduit**

1. Feed the actuator cables through the field supplied electrician's fitting and conduit.
2. Thread the electrician's fitting into the actuator and secure the conduit to the fitting in accordance with local building code requirements.

### Setup and Adjustments

#### Mode Selection Switch

Actuators have an external mode selection switch to reverse control logic. The switch is accessible from both A and B sides of the actuator as illustrated in Figure 12. Actuators are delivered in Direct Acting (DA) mode and can be switched by the user to Reverse Acting (RA) mode.

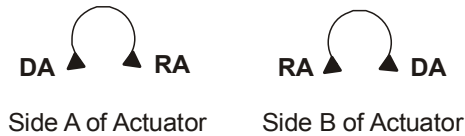

**Figure 12: Mode Selection**

#### Control Response

The installation side of the actuator and the position of the mode selection switch combine to determine control response from the actuator. See Figure 13.

Control Inputs		Installation Side			
GRY 3	ORN 4	A		B	
		Mode Selection Switch		Mode Selection Switch	
		DA	RA	RA	DA
CLOSED	OPEN	↘	↙	↘	↙
OPEN	CLOSED	↙	↘	↙	↘
OPEN	OPEN	STOP	STOP	STOP	STOP
CLOSED	CLOSED	↘	↙	↘	↙

**Figure 13: Control Response**

### Auxiliary Switches

The (-A) models include one integral auxiliary switch with a switch adjuster accessible on either face of the actuator (see Figure 2 and Figure 3). The factory setting for the Auxiliary Switch is 11° closing (relative to the 0 to 90° rotation range as printed on the product label).

The switch point is continuously adjustable throughout the actuator's rotation range. For the most accurate switch positioning, see Figure 14 and use the method in the following example.

To change the switch point, proceed as follows:

1. Position the actuator in the full spring return position.

**Note:** The switch is factory set to trip when the actuator reaches the 11° position.

2. Rotate the switch adjuster until it points to the desired switch point.

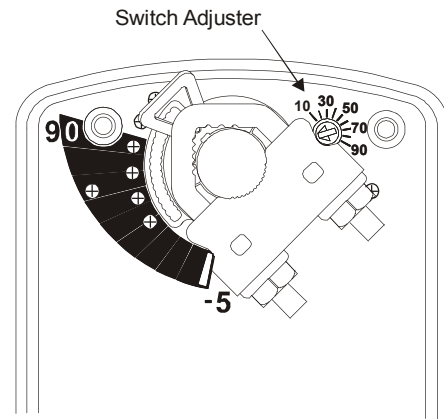

**Figure 14: Switch Trip Point Settings**

3. Connect the Auxiliary Switch to a power source or an ohmmeter and apply power to the actuator. The actuator moves to the fully open position and holds while power is applied.

4. Observe the switch point. If required, repeat Step 1 through Step 3.